

THE GLENN L. MARTIN COMPANY.  
CLEVELAND, OHIO.  
1918 "MARTIN BOMBER" U.S. AIR SERVICE  
2-400 H.P. LIBERTY-12 MOTORS 118 M.P.H.

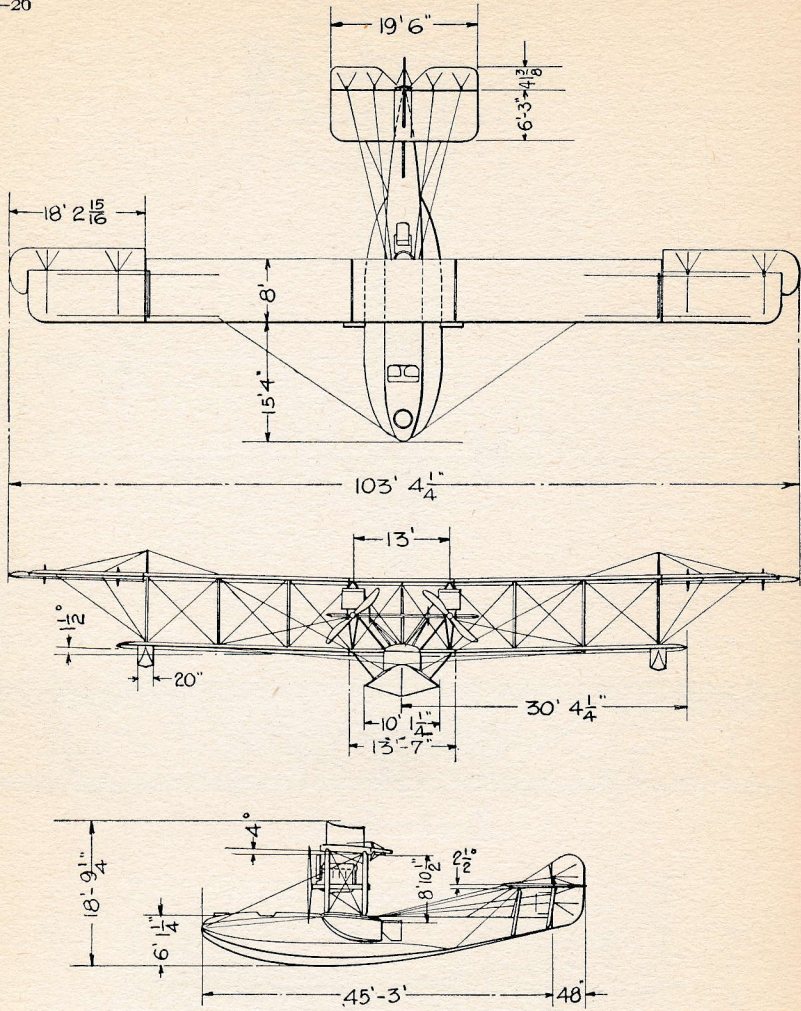



NAVAL AIRCRAFT  
BUREAU OF CONSTRUCTION AND REPAIR  
MODEL "F.5-L" 1918-2 LIBERTY 12 330(EACH) H.P.  
MOTOR 5 90 M.P.H.



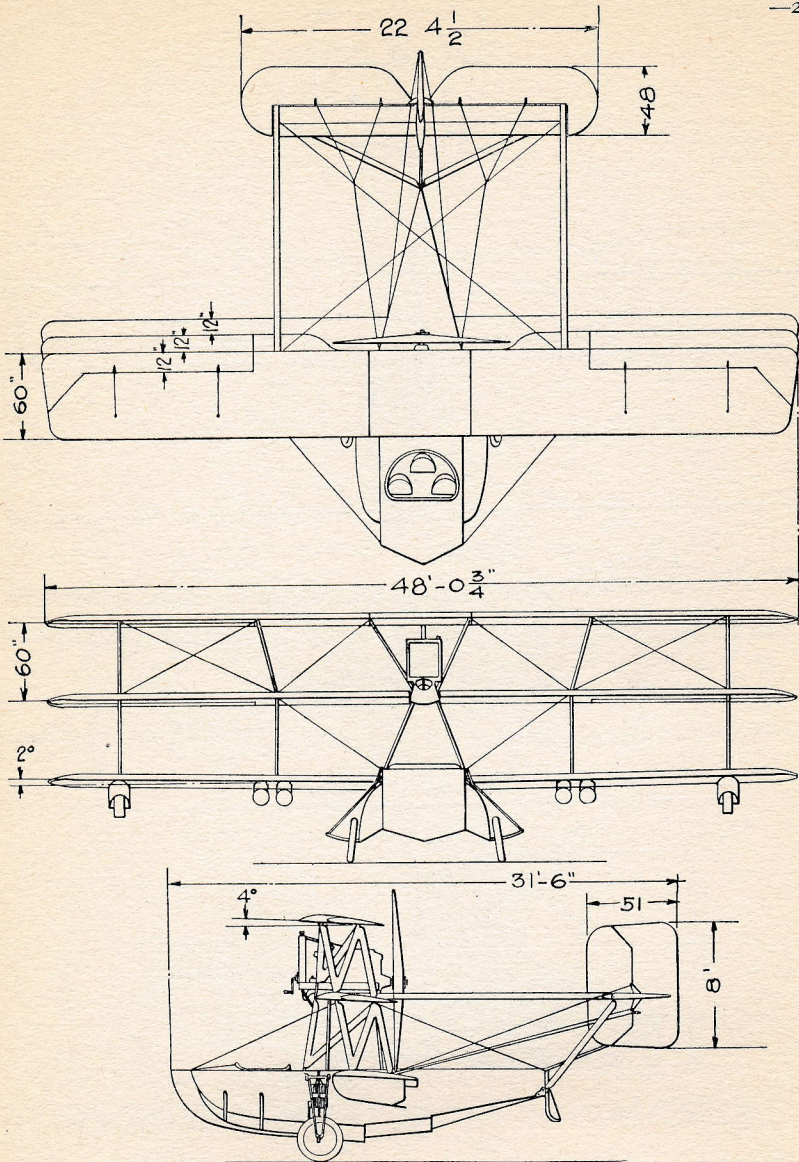

SPERRY AIRCRAFT CORPORATION  
FARMINGDALE , L.I. N.Y.  
"AMPHIBIAN" OCT. 1918-LIBERTY 12 CYL. MOTOR-370 H.P.85M.P.H.



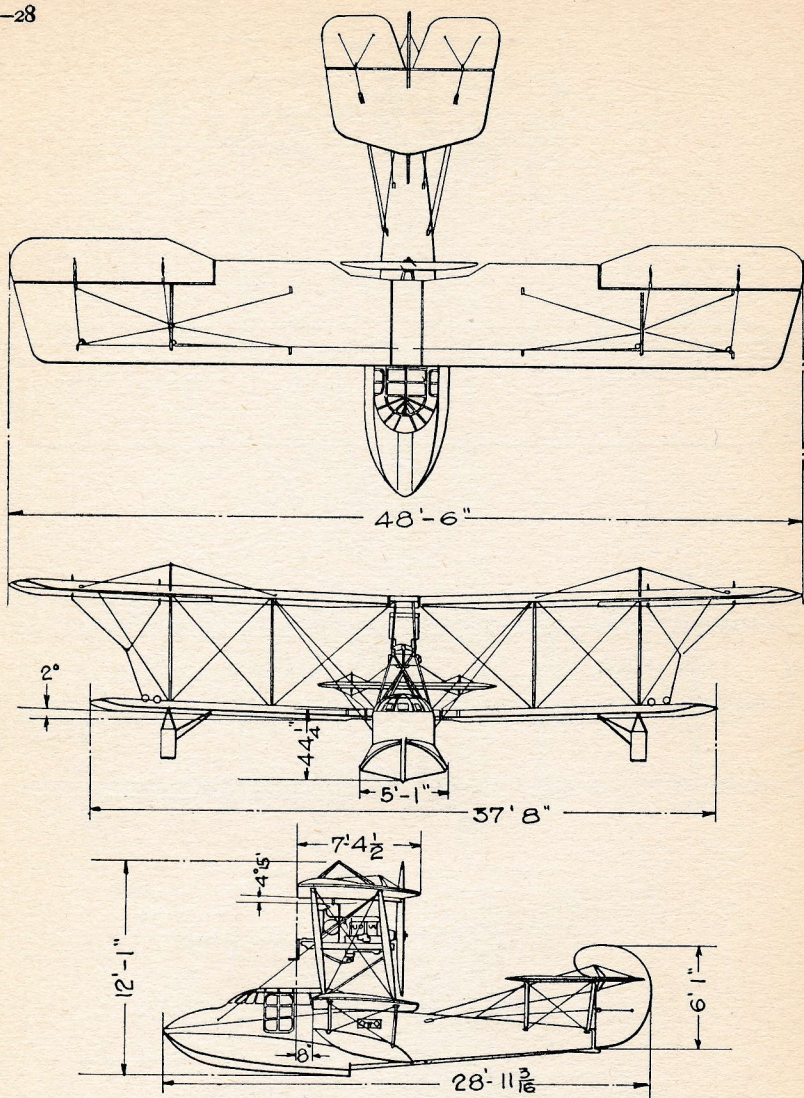

AEROMARINE PLANE & MOTOR COMPANY  
KEYPORT N.J.  
MODEL "50.B-2" 1919-AEROMARINE "U-8" 180 H.P.  
(RATED) 200 H.P. (DELIVERED) 85 M.P.H.



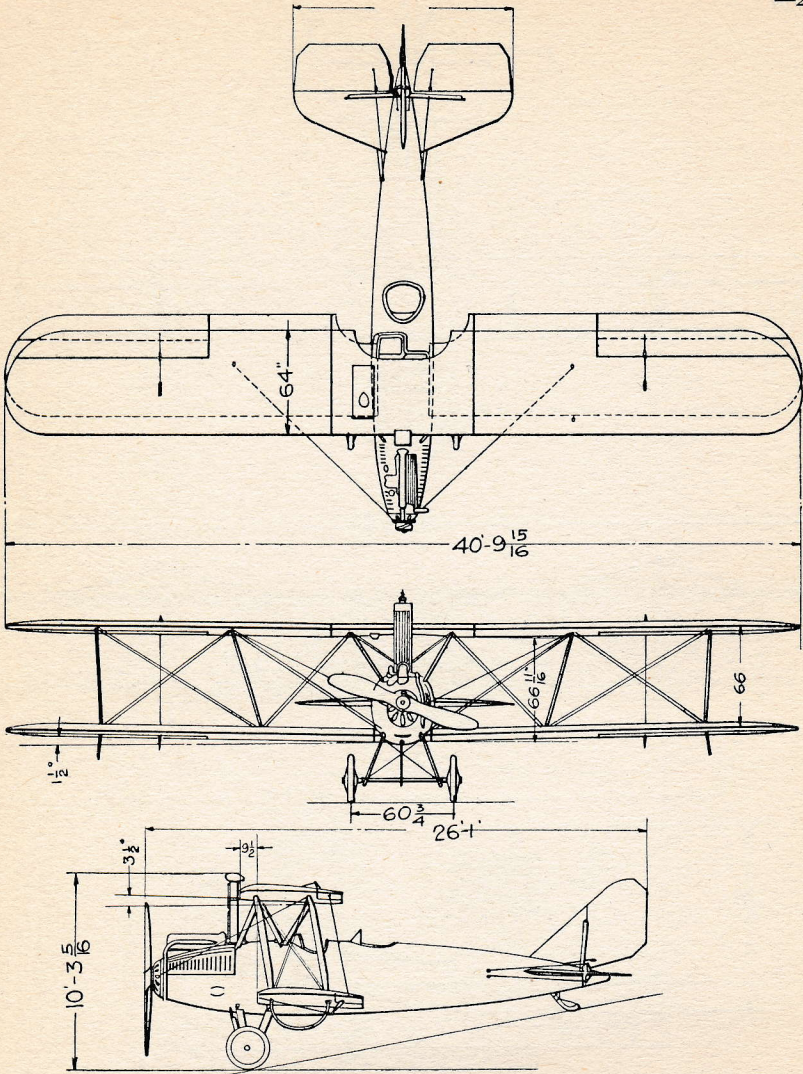

THE CURTISS AEROPLANE AND MOTOR CORPORATION  
GARDEN CITY, L.I.N.Y.

THE CURTISS "ORIOLE" 1919 - CURTISS "C6" 6 CYL. 150  
H.P. MOTOR - 96 M.P.H.



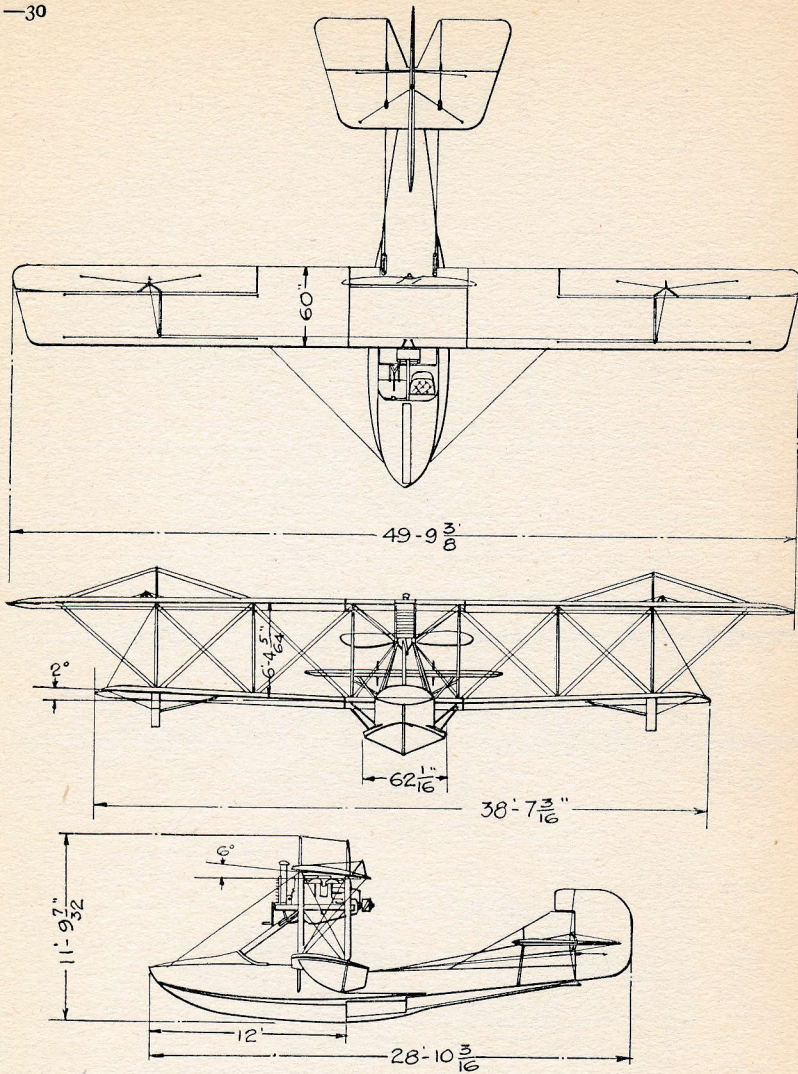

THE CURTISS AEROPLANE AND MOTOR CORPORATION  
GARDEN CTY L.I.N.Y.  
CURTISS "SEAGULL" 1919-CURTISS "G6" 150 H.P. MOTOR 76 M.P.H.



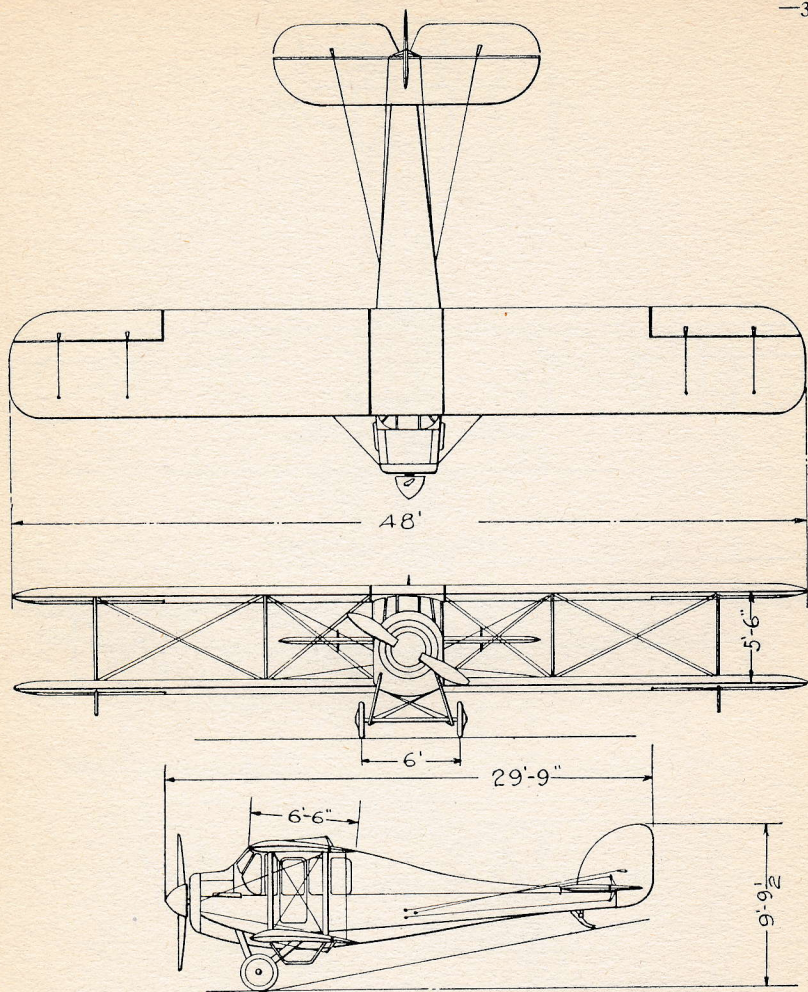

DAYTON WRIGHT COMPANY  
DAYTON, OHIO.

MODEL "O.W." 3 PLACE "AERIAL COUPE" 1919-WRIGHT  
MOD. "E" 8 CYL. 180 H.P. MOTOR 102 M.P.H.



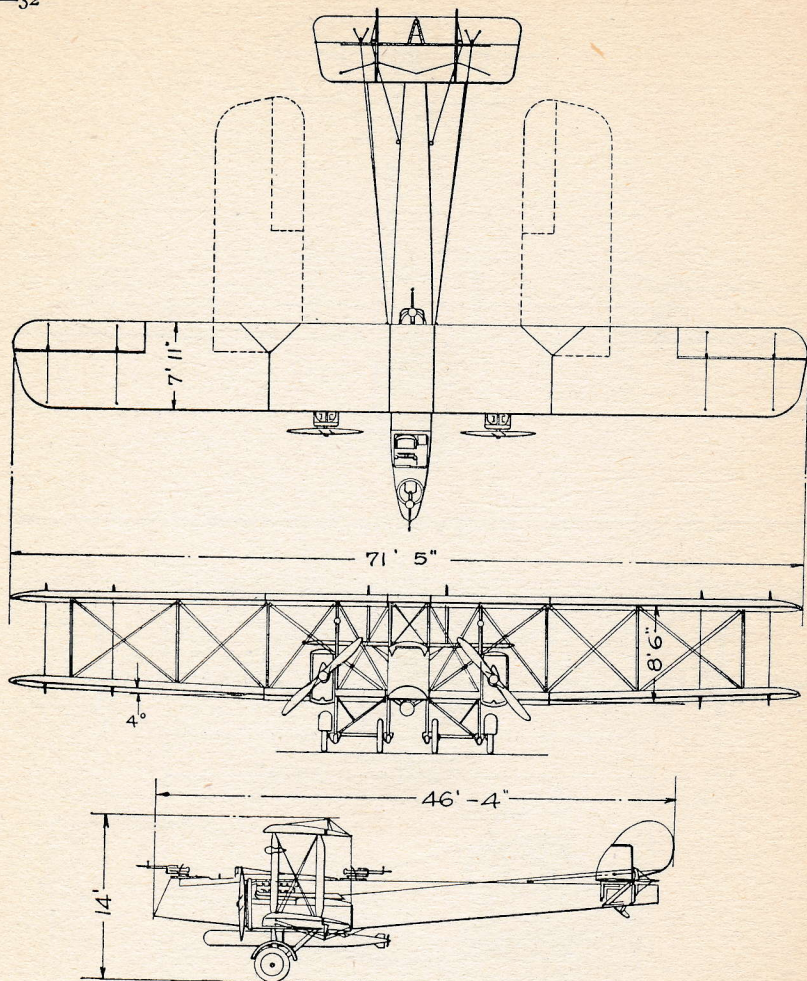

THE GLENN L. MARTIN COMPANY  
CLEVELAND, OHIO.  
MODEL "M.T." TORPEDO PLANE 1919-2 LIBERTY  
400 H.P. (EACH) MOTORS 114 M.P.H



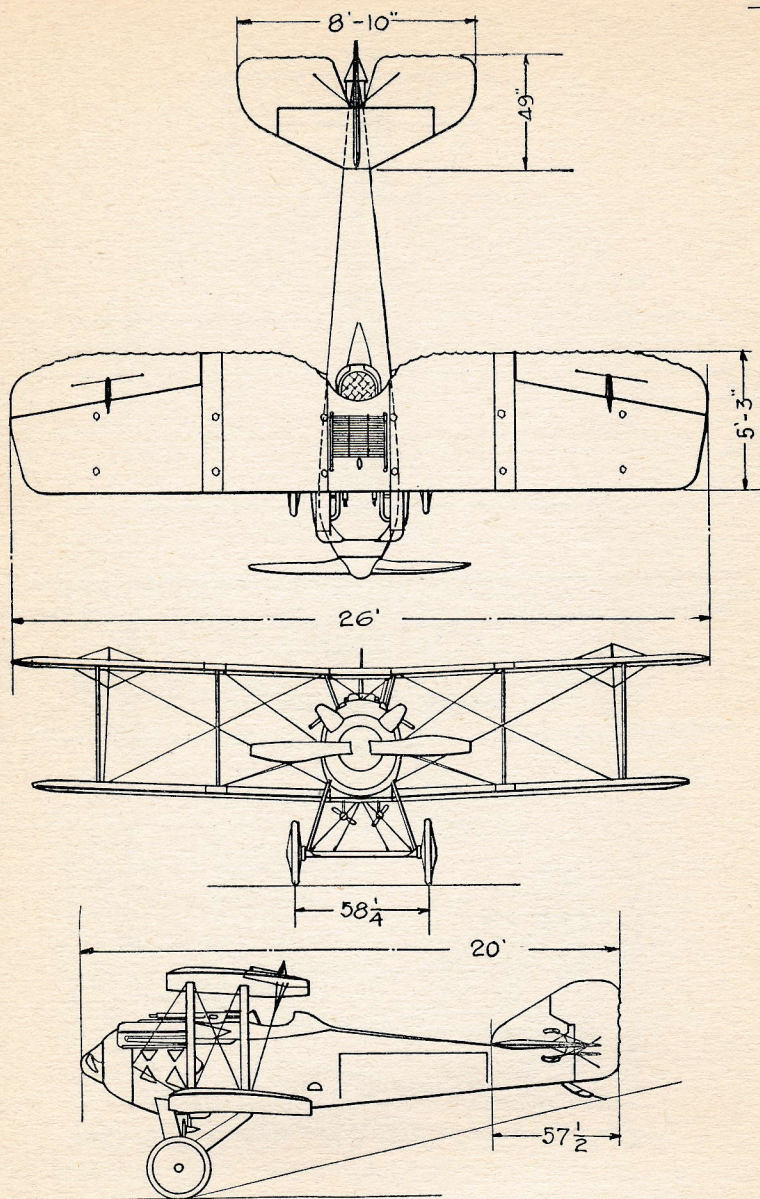

THOMAS-MORSE AIRCRAFT CORPORATION  
ITHACA, N.Y.

MODEL "M.B.-3" 1919 - WRIGHT, 300 H.P. 8 CYL.  
MOTOR - 168 M.P.H. IN PULITZER RACE.



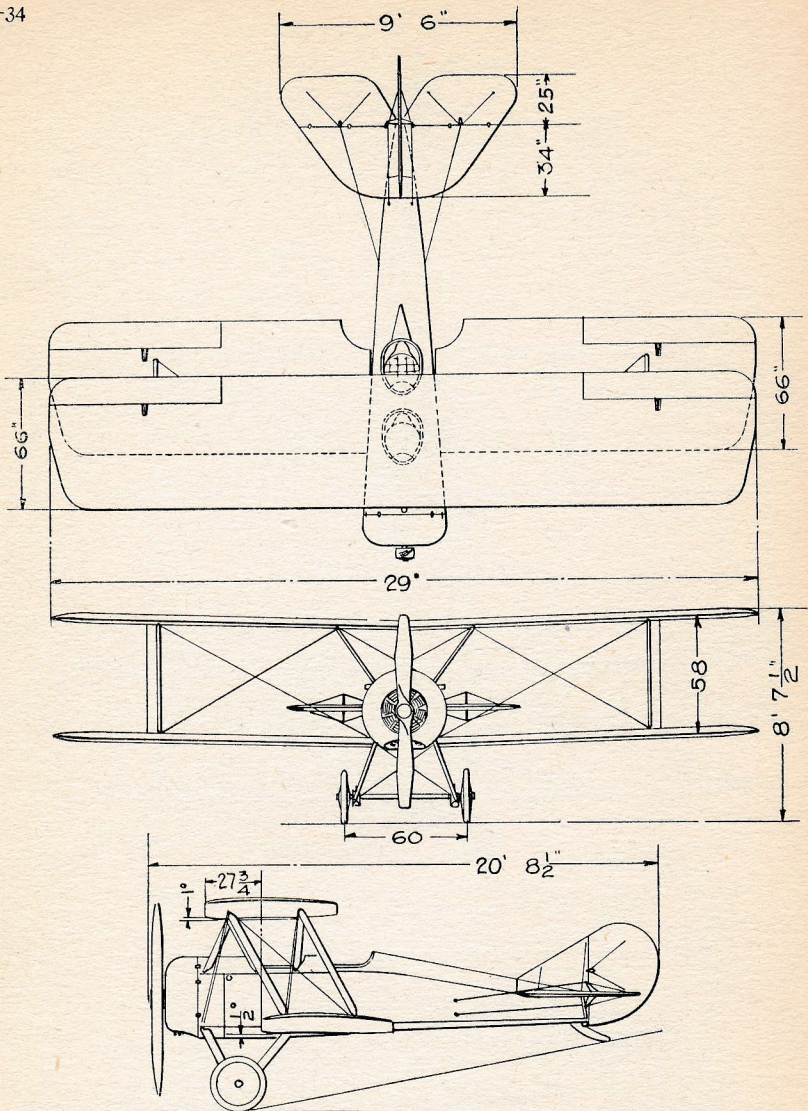

THOMAS-MORSE AIRCRAFT CORPORATION  
ITHACA, N.Y.  
MODEL "S-6" FEB. 1919 - LE RHONE 80 H.P. ROTARY  
MOTOR 105 M.P.H.



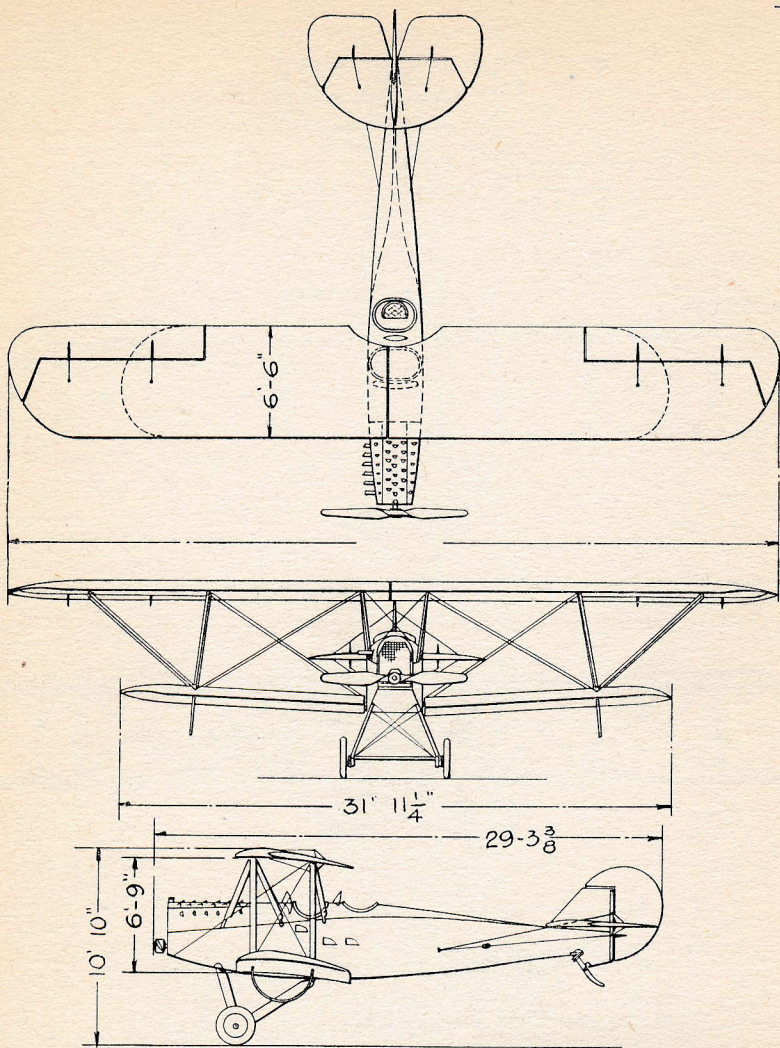

BOEING AIRPLANE COMPANY  
SEATTLE, WASH.

"MOUNT RAINIER" BBL-3 1920-HALL-SCOTT "L-6" MOTOR  
200 H.P. 100 M.P.H.



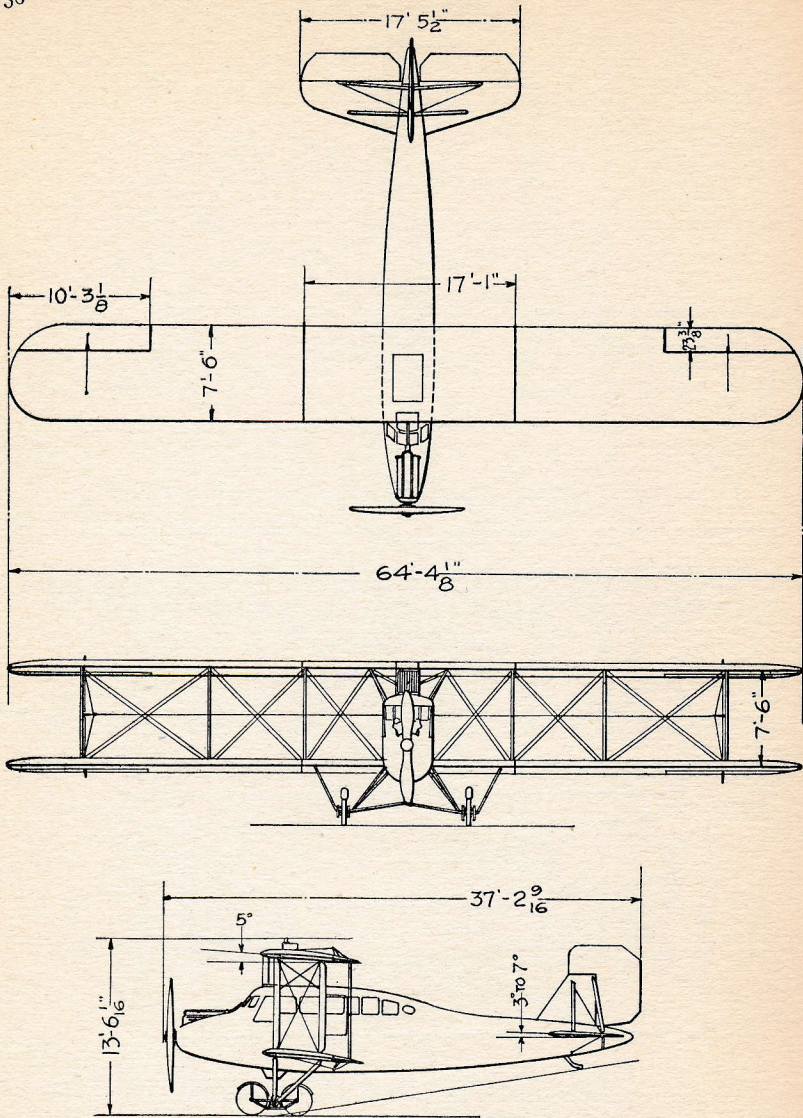

THE CURTISS AEROPLANE AND MOTOR CORPORATION  
GARDEN CITY L.I.N.Y.  
CURTISS 10 PASSENGER "EAGLE" 1920-CURTISS "C-12"  
OR "LIBERTY 12" MOTOR-400 H.P.-100 M.P.H.



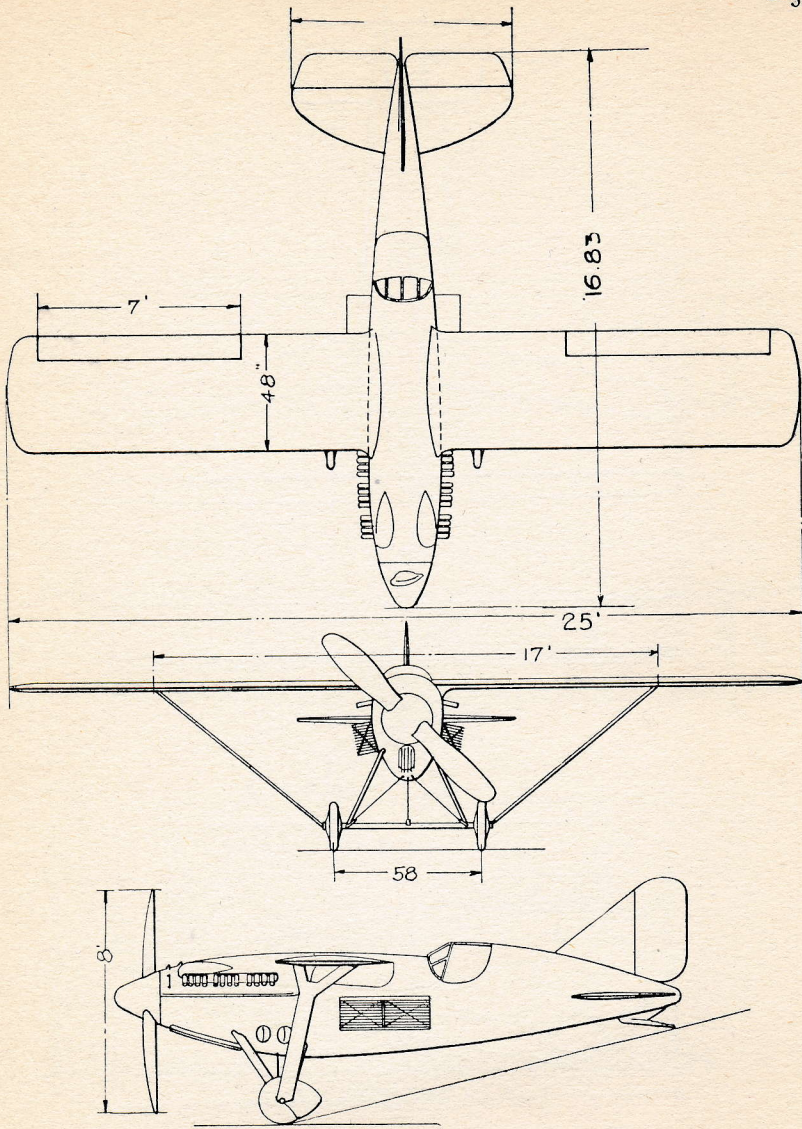

THE CURTISS AEROPLANE AND MOTOR CORPORATION  
GARDEN CITY, L.I.N.Y.

CURTISS "WILDCAT" - 1920 CURTISS C-12 400 H.P. MOTOR  
BUILT FOR S.E.J. COX. FOR GORDON BENNETT RACE.



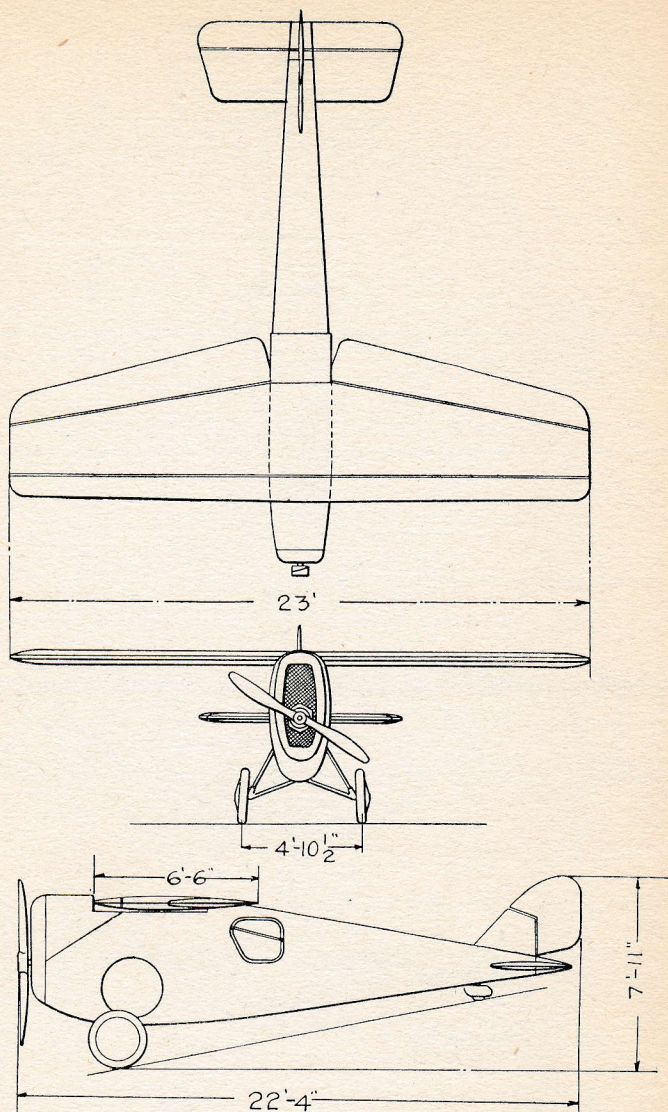

DAYTON WRIGHT COMPANY  
DAYTON OHIO  
MODEL "RB" MONOPLANE-1920 GORDON BENNETT ENTRY- HALL  
SCOTT & CYL. 240 H.P. MOTOR APPROX. SPEED 195 M.P.H.



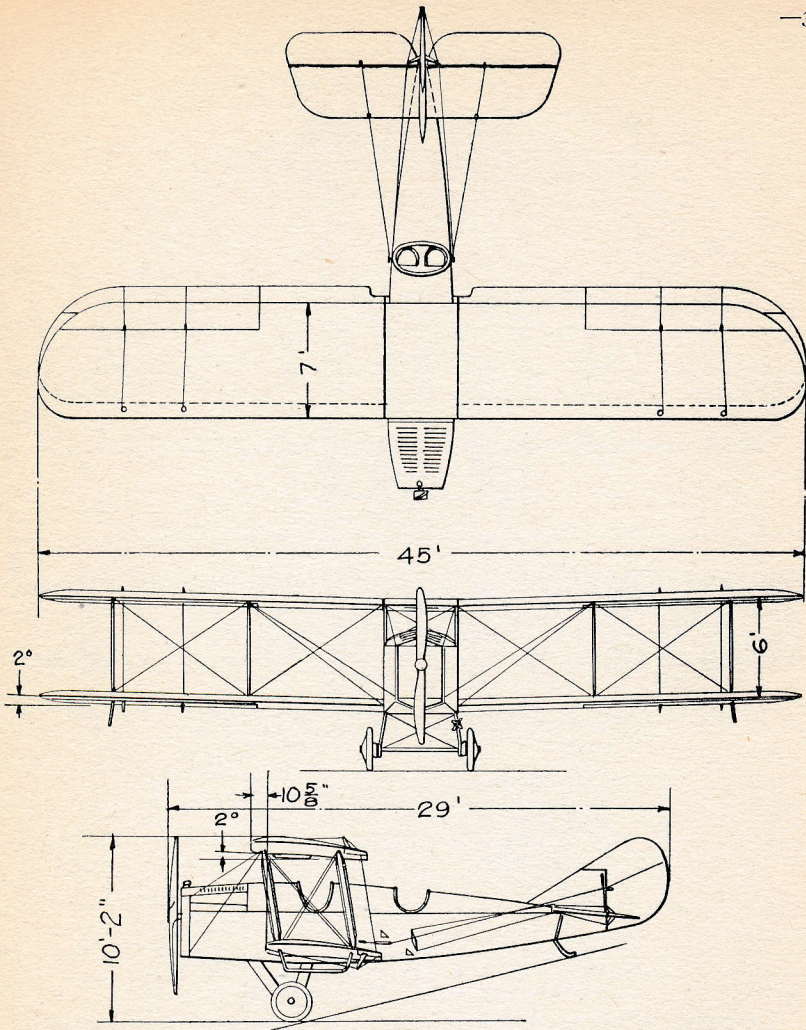

GALL-AUDET AIRCRAFT CORPORATION  
EAST GREENWICH, R. I.

MODEL C-3 "LIBERTY TOURIST" 1920-1, 400 H.P.  
LIBERTY MOTOR



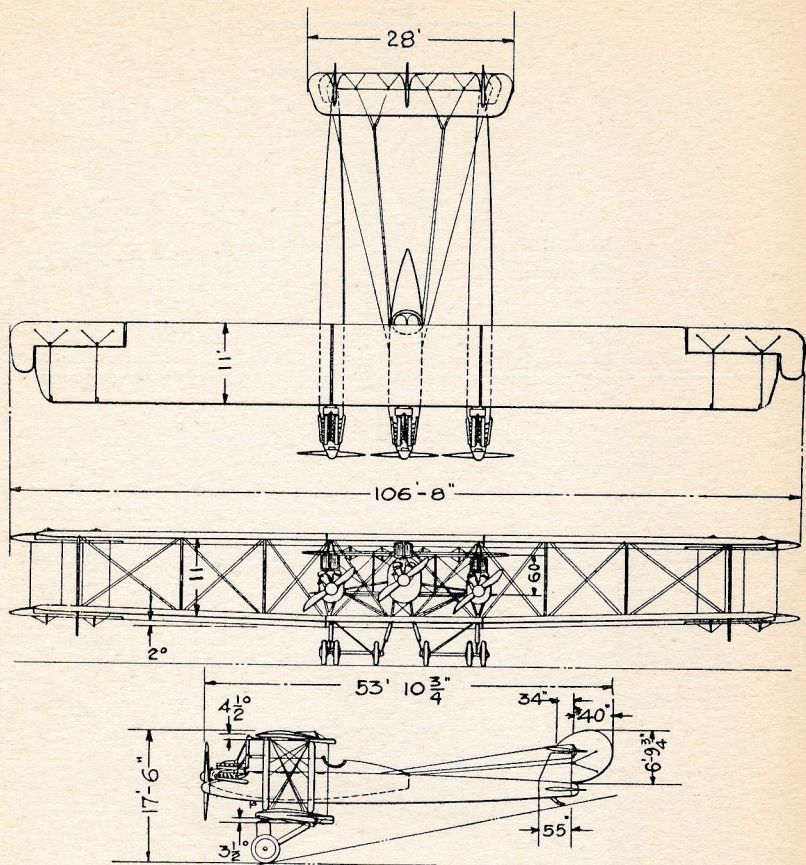

L.W.F. ENGINEERING COMPANY.  
NEW YORK - COLLEGE POINT L.I.N.Y.  
MODEL "H" GIANT BOMBER 1920. U.S. AIR SERVICE - 3-400  
H.P. (EACH) LIBERTY MOTORS 110 M.P.H.



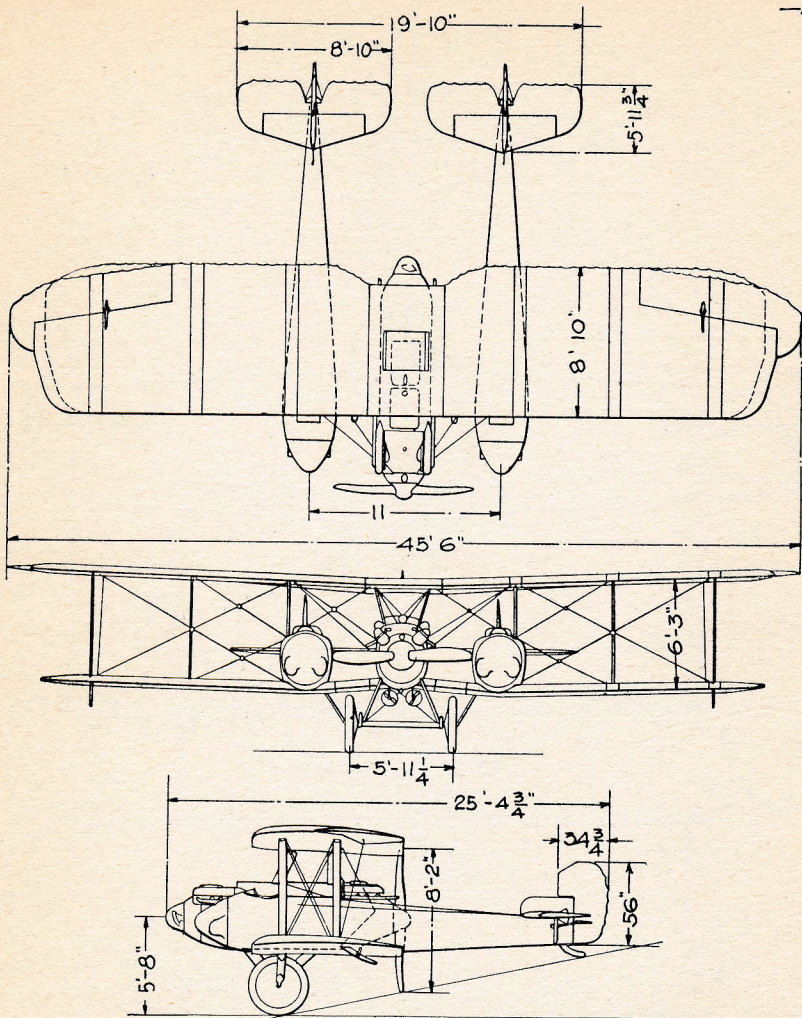

THOMAS-MORSE AIRCRAFT CORPORATION  
ITHACA, N. Y.

MODEL "M.B.4" FEB. 1920-2, 300 H.P. WRIGHT MOTORS



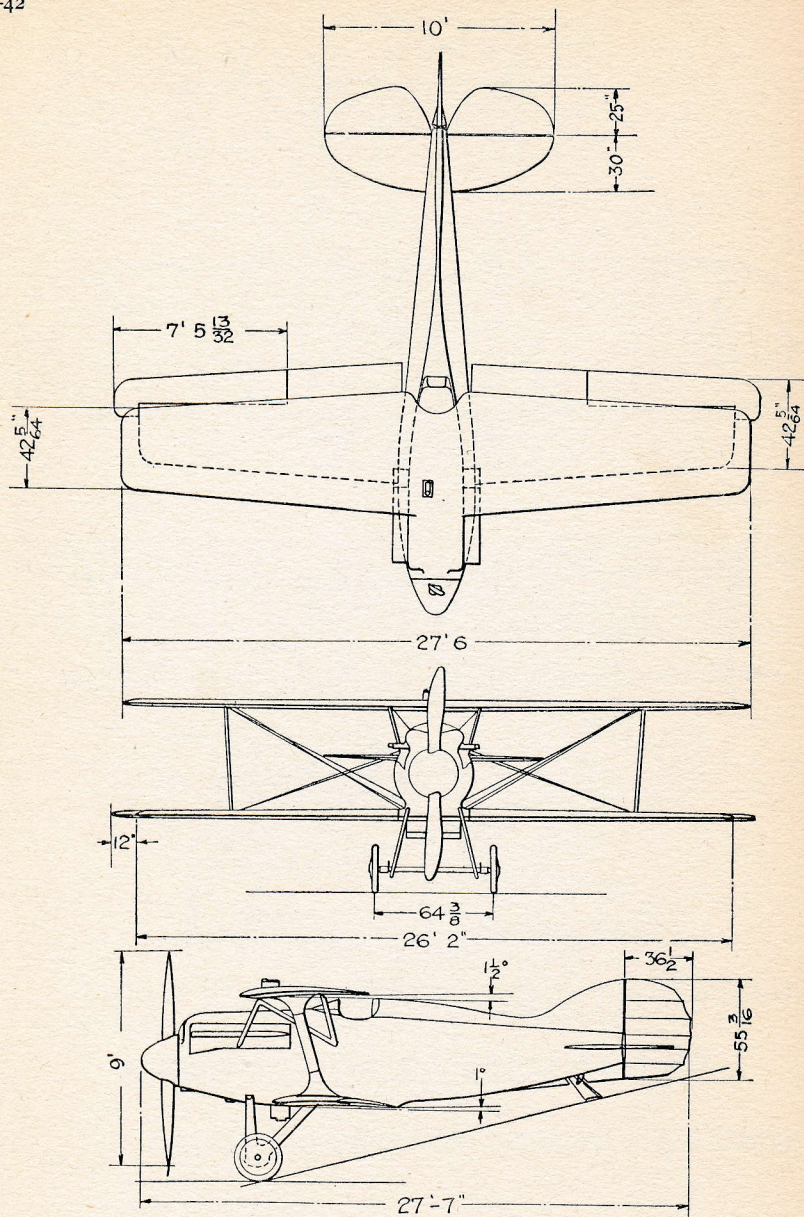

"VERVILLE-PACKARD  
U.S. AIR SERVICE 1920 GORDON BENNETT  
ENTRY 2025 PACKARD 12 CYL. 600 H.P. MOTOR 178.80  
M.P.H. IN PULITZER RACE



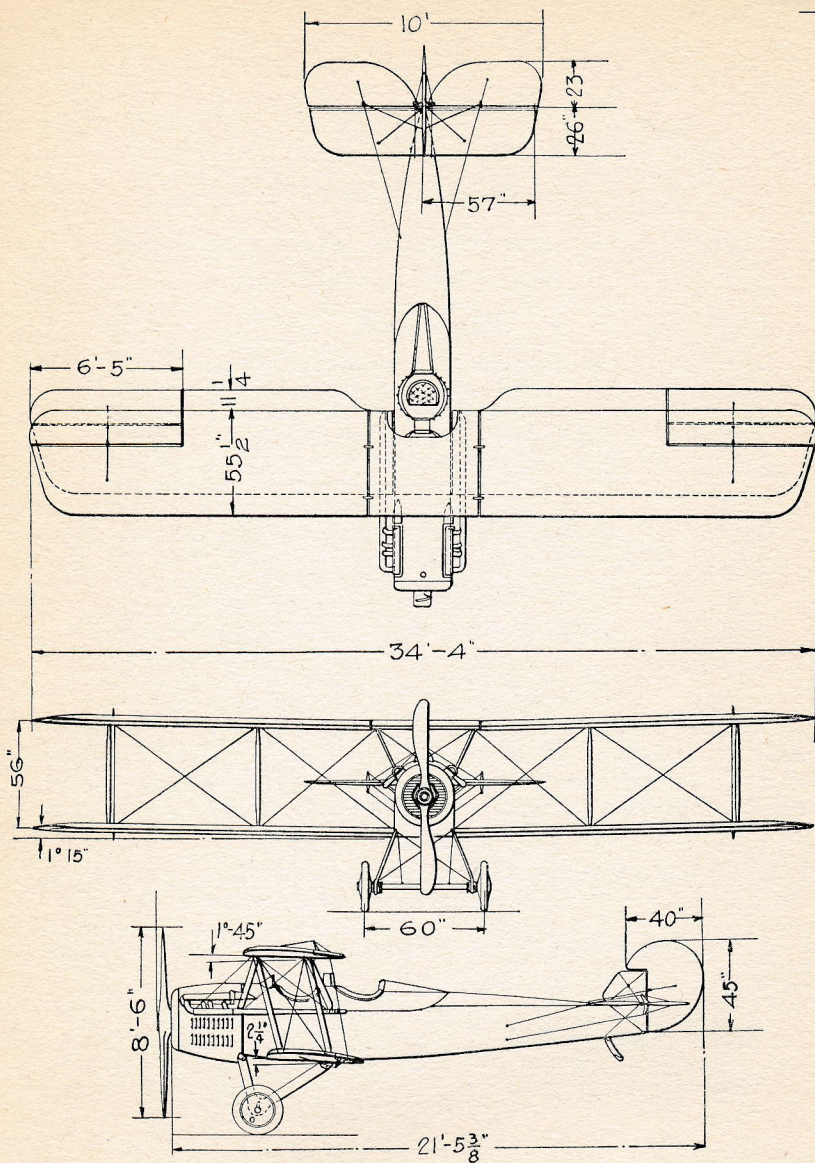

LEWIS & VOUGHT CORPORATION.  
LONG ISLAND CITY, L.I.N.Y.

MODEL V.E-7-1918-U.S. AIR SERVICE - WRIGHT 180 H.P.  
8 CYL. MOTOR 106 M.P.H.